

CADENAS AGRÍCOLAS TIPO S

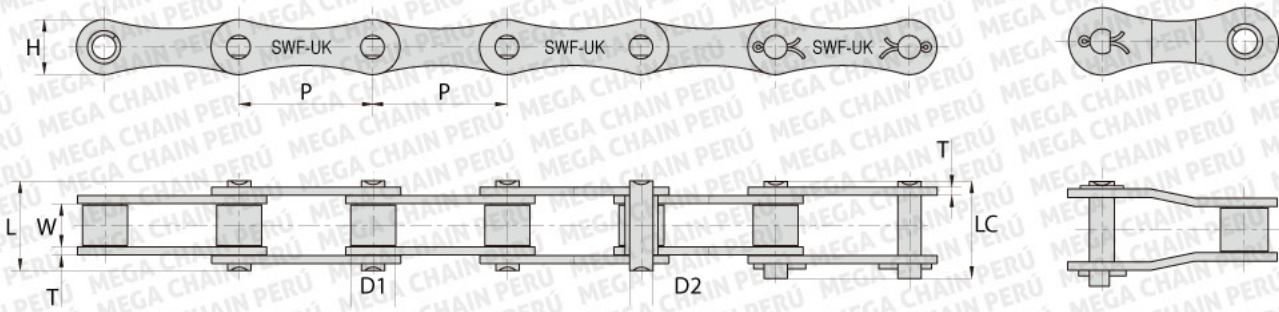

CADENA N°	Paso	Interior	Rodillo	Placa		Pin			*Carga admissible	Carga de Rotura	Peso Aprox.
	P	W	D1	Altura	Espesor	Diámetro	Longitud	Longitud Máx.			
	mm	mm	mm	H (mm)	T (mm)	D2 (mm)	L (mm)	LC (mm)	kg/m	kg/m	kg/m
S32	29.21	15.88	11.43	13.20	1.80	4.45	26.70	28.80	816	2203	0.86
S42	34.93	19.05	14.27	19.80	2.80	7.00	34.30	37.00	2753	5180	1.60
S45	41.40	22.23	15.24	17.30	2.80	5.72	37.70	40.40	1835	3681	1.66
S51	38.10	16.00	15.24	17.30	2.80	5.72	30.90	33.80	2855	3141	1.48
S52	38.10	22.23	15.24	17.30	2.80	5.72	37.70	40.40	1835	3681	1.68
S55	41.40	22.23	17.78	17.30	2.80	5.72	37.70	40.40	1835	3681	1.80
S62	41.91	26.20	19.05	17.30	2.50	5.72	40.30	43.00	2723	3681	1.87
S77	58.34	22.23	18.26	26.20	4.00	8.90	43.20	46.40	4589	7454	2.66
S88	66.27	28.58	22.86	26.20	4.00	8.90	49.80	53.00	4589	7454	3.25

* La carga de trabajo ideal es el 20% de la capacidad de carga admisible.